

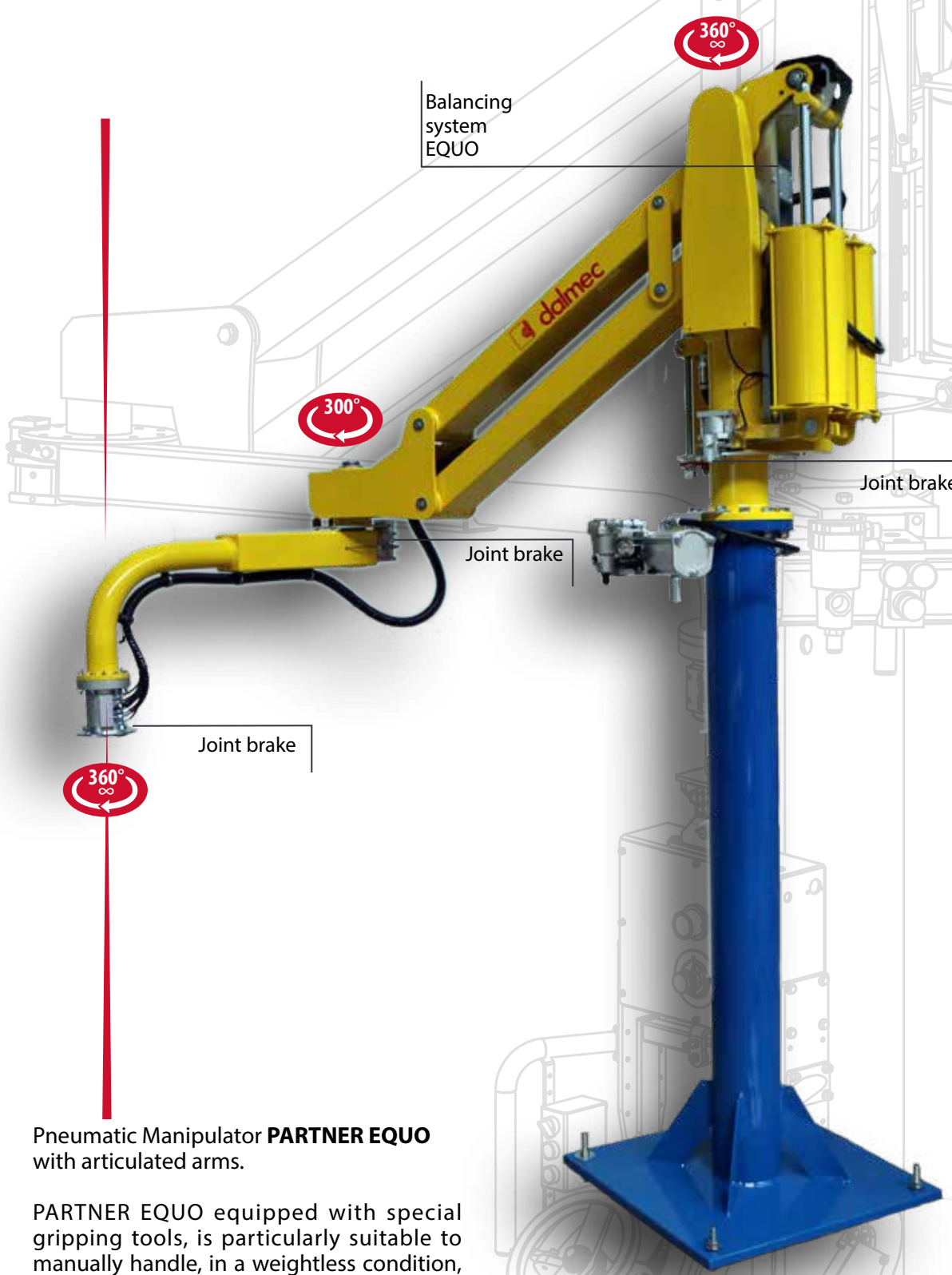

dalmec

Industrial Manipulators



Balancing system EQUO

360°
∞

300°

Joint brake

Joint brake

Joint brake

360°
∞

WEIGHT CAPACITY
550 Kg

RADIUS
4000 mm

PRESSURE
0.7-0.8 Mpa

LOAD OFF-SET

VERTICAL LIFT
2450 mm

VERSIONS
COLUMN
FIXED OVERHEAD
RUNNING OVERHEAD

Pneumatic Manipulator **PARTNER EQUO** with articulated arms.

PARTNER EQUO equipped with special gripping tools, is particularly suitable to manually handle, in a weightless condition, center and off-set loads in any direction.

PARTNER EQUO[®] - PE

Partner column mounted - PEC

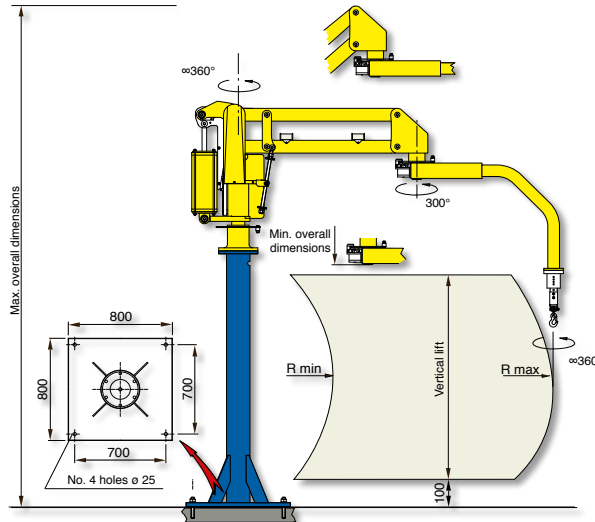

Structural versions: column mounted on fixed base-plate, autostable base-plate of our supply properly dimensioned or with autostable motorised trolley that translates on a simple profile track on the floor.

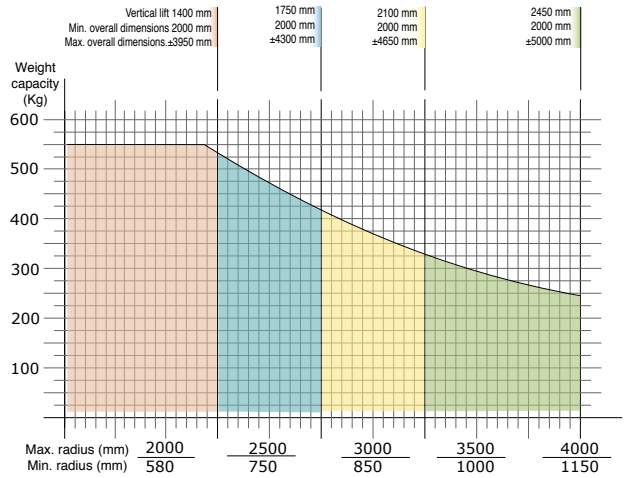

Partner overhead mounted - PEF

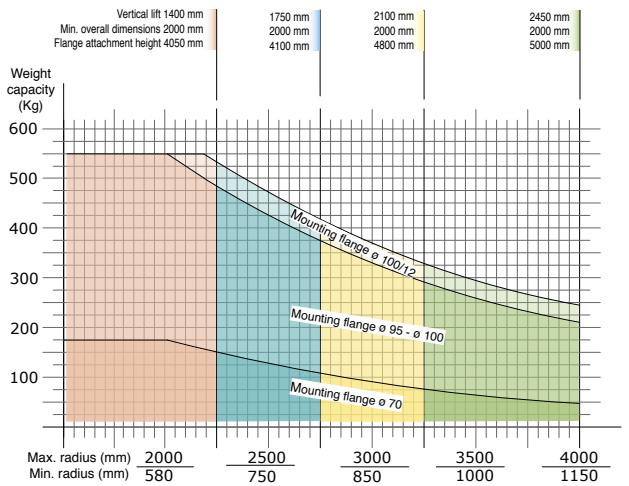
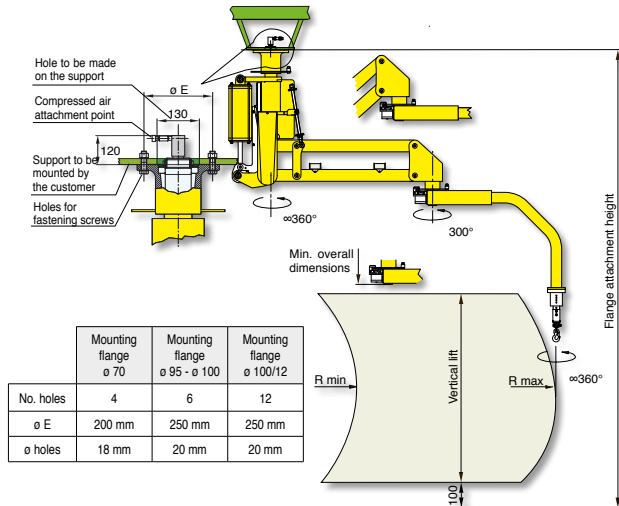

Partner overhead trolley mounted - PES

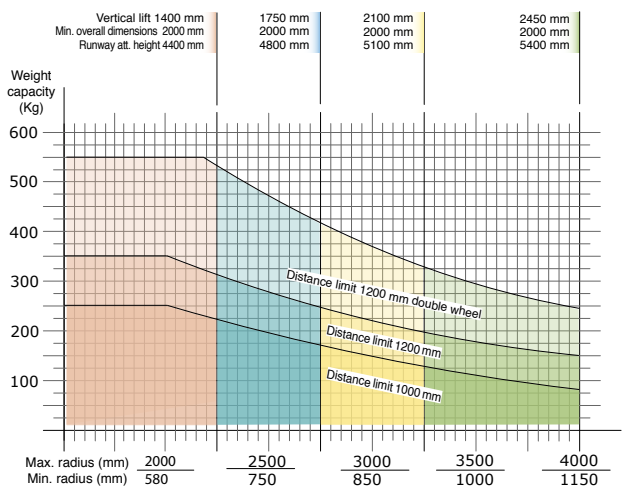
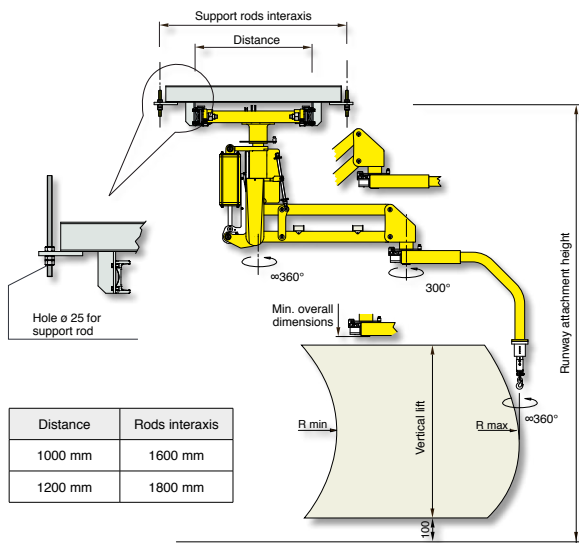

Air supply: Dry and oil-free compressed air min constant 0.7-0.8 MPa